

# ***GReddy Turbo Kit***

HONDA Civic Si FG2 (K20Z) T517Z 8cm<sup>2</sup>

# HONDA Civic Si FG2 (K20Z) T517Z 8cm<sup>2</sup>

## Installation Manual

**Please read the entire manual before installing this kit.**

Application:

Make	Model	Chassis	Year
HONDA	Civic Si	FG2	06~on

- This **GReddy Turbo Kit** is designed only for the vehicles specified above.
- Premium grade gasoline (91 octane or higher) is required with this Kit.
- Make sure that the vehicle is not equipped with any ECM upgrade chips.
- Use of **GReddy Racing Spark Plugs ISO #7** or NGK plugs (colder than factory) is recommended with this kit.

### Important

- This installation should only be performed by a trained specialist who is very familiar with the automobile's mechanical, electrical and fuel management system.
- If installed by an untrained person, it may cause damage to the kit as well as the vehicle.
- GReddy Performance Products Inc. is not responsible for any damage to the vehicle's electrical system caused by improper installation.
- This kit is for off-road use vehicle only which may never be driven on a public highway

## 1. PARTS LIST

1.Turbocharger	T517Z	8c m <sup>2</sup>	P565		1
2.Exhaust manifold			(Cast Ductile Iron)		1
3.Downpipe			(Cast Ductile Iron, 60 φ Steel)		1
4.Intercooler			(THE31C)		1
5.Suction Pipe			(60 φ Aluminum)		1
6.TZ Suction Flange			(60 φ Aluminum)		1
7.Compression Pipe		C-1	(50 φ Aluminum)		1
8.	"	C-2	(50 φ Aluminum)		1
9.	"	C-3	(50 φ Aluminum)		1
10.	"	C-4	(50 φ Aluminum)		1
11.	"	C-5	(50 φ Aluminum)		1
12.	"	C-6	(50 φ Aluminum)		1
13.	"	C-7	(50 φ Aluminum)		1
14.	"	C-8	(60 φ Aluminum)		1
15.Airinx	AY-MB		(Blue Filter)		1
16.Airinx Hose Adapter			(M80)		1
17.Air Flow Sensor Housing					1
18.Oil Pressure Line	SUS	600mm			1
19.Oli Pressure Banjo Fitting	Small		(Male&Female)		1
20.Copper Washer		10 φ	T=1.0		2
21.Oli Pressure Fitting	3-Way	1/8PT			1
22.	"	1/8PT	— 1/8PT		1
23.	"	1/8PT	— 1/8PF		1
24.Oil Return Flange Pipe		16 φ	(Turbo)		1
25. Oil Return Banjo Fitting		16 φ	(Engine) Male&Female		1
26. Oil Return Banjo Spacer					1
27. Copper Washer		15.5 φ	T=1.0		3
28.Vacuum Fitting		5 φ	— 1/8PT		1
29.3-Way Vacuum Fitting		8 φ	— 4 φ — 8 φ	NORMA TRS 8-4-8	1
30. Hose	5 φ	350mm	(Actuator350mm)		1
31. "	12 φ	430mm	(EVAP)		1
32. "	16 φ	300mm	(Blow-by)		1
33.Oil Return Hose	16 φ	330mm			1

34.	Silicone Hose	50 φ × 70mm	Straight						5
35.	"	60 φ × 70mm	Straight						1
36.	"	50 φ - 60 φ	Reducer						3
37.	"	60 φ - 65 φ	Reducer						1
38.	"	60 φ - 80 φ	Reducer						1
39.	Hose band	12 φ	#8						2
40.	"	16 φ	#10						4
41.	"	50 φ	#32						13
42.	"	60 φ	#36						7
43.	"	65 φ	#40						1
44.	"	80 φ	#48						2
45.	Gasket	Turbo Inlet							1
46.	"	Turbo Outlet							1
47.	"	Turbine Inlet							1
48.	"	Turbine Outlet							1
49.	"	Downpipe							1
50.	"	Oil Return							1
51.	e-manage ultimate	US-FG2							1
52.	e-manage ultimate	Harness	(H-9)						1
53.	A/F Sensor Adapter								1
54.	Pressure Sensor Orifice	LF23-01							1
55.	Injectors	370cc	(Spacer × 2, Stud Bolt × 2, O ring × 8)						4
56.	Injectors Plug-In Harness	Honda-RC Type							4
57.	Heatshield 1	Turbo							1
58.	Heatshield 2	Down pipe							1
59.	Heatshield 3	Fire wall							1
60.	Thermo Cloth	100 × 1000mm							3
61.	Zip ties	150mm							10
62.	Zip ties	400mm							3
63.	Heatshield 3 Bracket								1
64.	Intercooler Core Bracket	L·R							1
65.	Oil Return Hose Bracket								1
66.	Aluminum Spacer	(T=8mm)	HH07-02						1
67.	Aluminum Spacer	(T=30mm)	LK08-11						3
68.	M4 × 10 P=0.7	Stainless Cap B	— — —				(Air Flow Sensor Housing)		2

69.M6 × 10	P=1. 0	Stainless	B	S/W	F/W	—	(Down pipe Heatshield)	2
70.M6 × 15	P=1. 0	Stainless	B	S/W	—	—	(Oil Return·Heatshield)	4
71.M6 × 15	P=1. 0	Stainless	B	S/W	F/W	—	(S-1,C-3 Bracket)	2
72.M6 × 45	P=1. 0	Stainless	B	S/W	F/W	—	(ECM)	3
73.M6	P=1. 0	Stainless	—	S/W	F/W	N	(Heatshield Bracket)	1
74.M6		Stainless	—	—	F/W	—	(Pressure Sensor Orifice)	1
75.M8 × 15	P=1. 25	Stainless	B	S/W	F/W	—	(Heatshield )	2
76.M8 × 20	P=1. 25	Stainless	B	S/W	F/W	—	(Suction·Intercooler)	6
77.M8 × 25	P=1. 25	Stainless	B	S/W	F/W	—	(Horn)	1
78.M8 × 30	P=1. 25	Stainless Stud	B	S/W	F/W	N	(C-1)	2
79.M8 × 30	P=1. 25	Stainless Stud	B	S/W	—	N	(Turbo in,out)	7
80.M8 × 75	P=1. 25	Stainless	B	S/W	—	—	(Turbo out)	2
81.M8	P=1. 25	Stainless	—	—	—	N	(Downpipe)	2
82.M10 × 45	P=1. 25	Stainless	B	S/W	F/W	N	(EX Manifold)	3

# 1. PARTS LIST

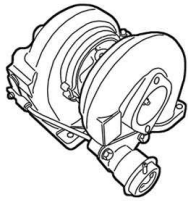

1

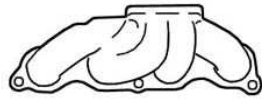

2

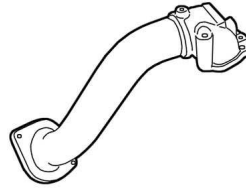

3



4



5



6



7



8



9



10



11



12



13



14

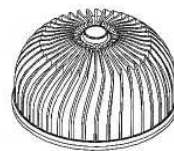

15

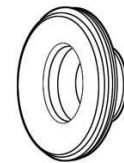

16



17



18

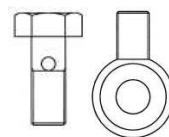

19



20

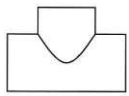

21



22, 23



24



25



26



27



28



29

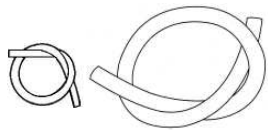

30~33

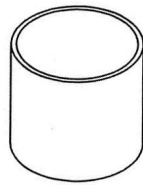

34, 35

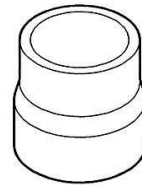

36~38



39~44

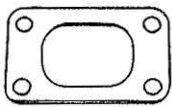

45

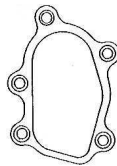

46

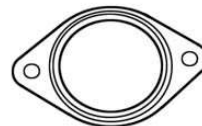

47

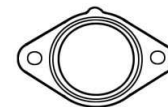

48



49



50



51



52

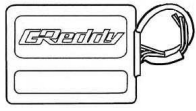

53

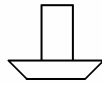

54

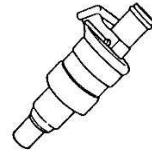

55



56

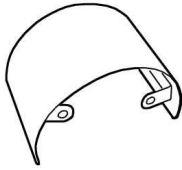

57

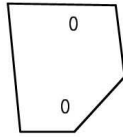

58



59

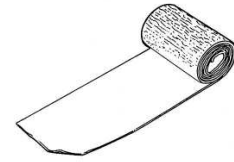

60



61.62



63



64

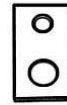

65

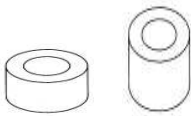

66, 67

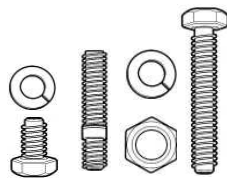

68~82



## 2. Removal of Stock Parts

When removing the stock parts, make sure you read over the factory repair manual for proper procedures.

- 2-1 Remove the battery.
- 2-2 Release the fuel pressure in the fuel system. (see factory repair manual for detail procedure).
- 2-3 Drain the engine oil.
- 2-4 Remove the cowl covers, and steel plate underneath.
- 2-5 Remove the engine cover.
- 2-6 Remove the Air cleaner assembly with intake tube, breather hose and mass air flow sensor.
- 2-7 Disconnect the primary and secondary O2 sensor and remove the catalytic converter.
- 2-8 Remove the exhaust manifold heat shield and manifold.
- 2-9 Remove the undercover and the front bumper.
- 2-10 Remove the bumper support beam and horns.

# 3. Kit Installation

## 3-1 e-Manage Ultimate Installation

- (1) Disconnect the ECM harness and remove the ECM.
- (2) Connect the E-manage Ultimate Plug and Play Harness to the ECM and plug the stock ECM harness into the Ultimate Plug and Play Harness.
- (3) Connect the A/F Sensor Adapter to the E-manage Ultimate Plug and Play Harness.  
(Part used #53)  
\*Blue wires are not directional.
- (4) Route the Ultimate harness along the Factory main Harness as shown.  
Route the harness through the fire-wall and Connect the E-manage Ultimate to the harness inside the vehicle.
- (5) Relocate the ECM forward using the provided Aluminum Spacer ,zip ties and M6 × 45mm bolts as shown.  
\*Avoid mounting the E-manage Ultimate unit in the area that would be exposed to direct sun light, moisture, or near heater outlet  
(Parts used #51,52,53,62,67,72)

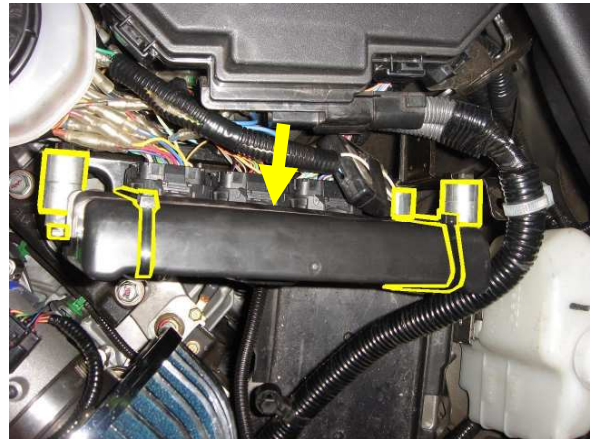
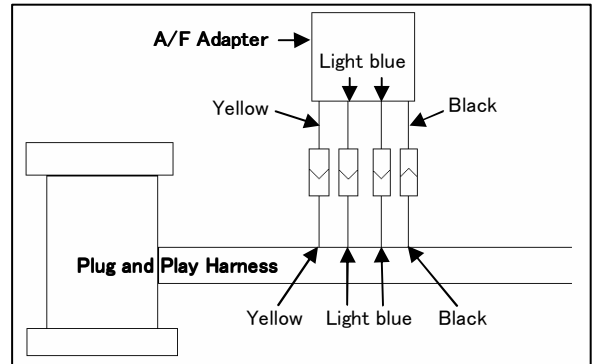

### Important

- This installation should only be performed by a trained specialist who is very familiar with the automobile's electrical and fuel management system.
- GReddy Performance Products Inc. is not responsible for any damage to the vehicle's electrical system caused by improper installation.

### Important !

Make sure the all the wire connections are correct. If they are connected incorrectly, it can damage the e-Manage Ultimate, ignition coils, and/or ECM.

### 3-2 Thermo Cloth Installation

- (1) Wrap the thermo cloth to the engine harness, e-manage Ultimate harness, the heater hoses, and brake lines by the firewall.  
(Parts used #60)



- (2) Wrap the thermo cloth to the fuel line and brake line by the firewall.

### Important !

- **Make sure the engine harness and e-manage ultimate harness are properly wrapped twice.**
- **Make sure to use safety wire to wrap the thermo cloth. Zip ties will melt from the heat and eventually will come off.**
- **GReddy Performance Products, Inc. will not be responsible for any damage caused due to improper installation.**
- **Make sure to check and double check this step. This is the most important step in this install.**

### 3-3 Heat shield 3 Installation

- (1) Install the heat shield bracket 3 on to the firewall as shown.

(Parts used #63,73)

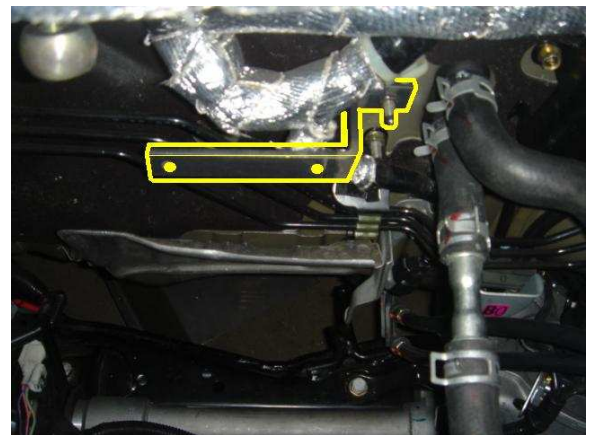

- (2) Install the heat shield 3 on to the firewall using the safety wire and provided M6 x 15mm bolts.

\* Be sure to wrap the brake line with the provided thermo cloth before installing the heat shield.

(Parts used #59,70)

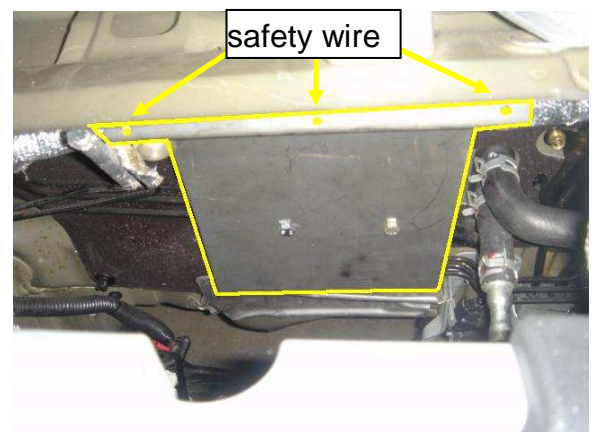

### 3-4 Oil Pressure Line Installation

- (1) Remove the Oil Pressure switch and install the union fitting and 3-way fitting on to the block.
  - \* Use Teflon tape on PT threads but not on the PF thread.

(Parts used #21,22,23)

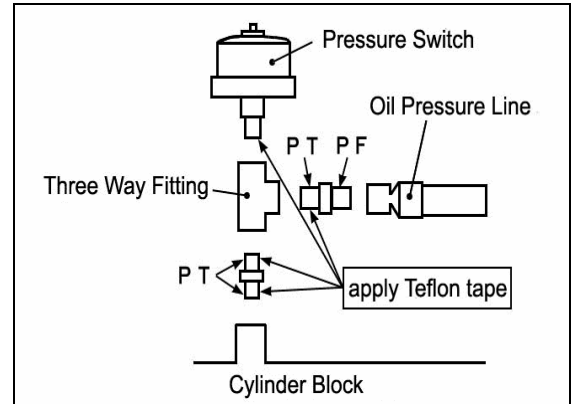

- (2) Install the oil pressure switch to the 3-way fitting.
- (3) Reconnect the oil pressure switch harness.
- (4) Connect the oil pressure line to the installed union fitting.

(Parts used #18)



### 3-5 Exhaust Manifold Installation

- (1) Install three stud bolts on to the cylinder head as shown.

(Parts used #82)

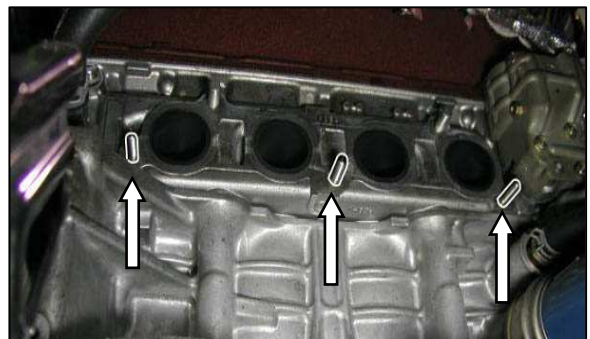

- (2) Install the exhaust manifold using the factory gasket.
  - \* Use a new exhaust manifold gasket.
  - \* Use factory nuts on the top side of the flange.

(Parts used #2, 82)





### 3-6 Turbocharger Installation

- (1) Wrap the thermo cloth the actuator as shown.
  - \* The heat off the manifold can damage the actuator with out the thermo cloth.
  - Use safety wire to secure the thermo cloth.
- (2) Install stud bolts on to the exhaust manifold, then mount the turbocharger to the manifold with compressor housing on the driver side. Using provided hardware and gasket.

(Parts used #1,45,60,79)

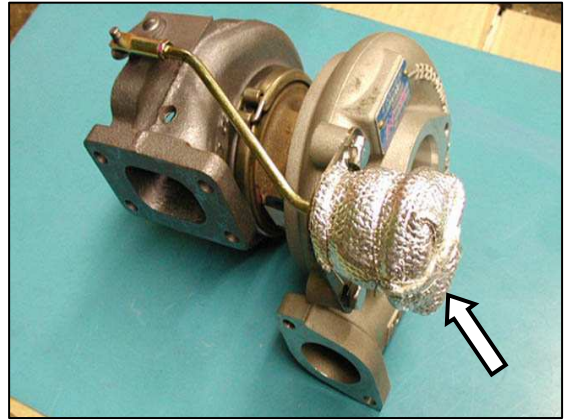

### 3-7 Oil Pressure Line Connection

- (1) Connect the oil pressure line that was installed in step 3-4 to the turbo using banjo fitting and copper washers. As shown.
  - \* Point the banjo fitting towards the firewall.

(Parts used #19,20)



### 3-8 Oil Return Installation

- (1) Install the provided oil return pipe to the turbocharger using the provided gasket and hardware as shown.

(Parts used #24, 46,50, 70)

- (2) Remove the oil drain bolt and install the provided oil return banjo bolt using spacer and copper washers as shown.

(Parts used #25, 26, 27)

- (3) Wrap the provided 16  $\phi$  hose with thermo cloth. Then Install the hose to connect the oil return pipe from the turbo to the oil return banjo fitting on the oil pan.

\*Route the hose behind the intermediate drive shaft as shown.

(Parts used #32, 40, 60)

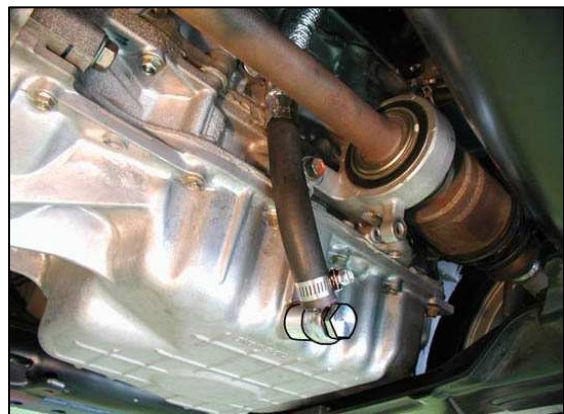

(4) Install the Oil return hose bracket to the block and secure the hose to the bracket using provided zip ties as shown.

(Parts used #61, 65)

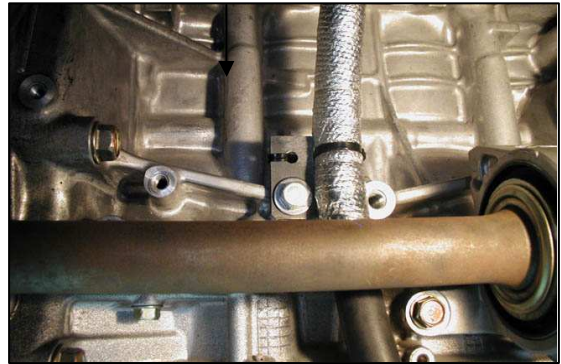

(5) Modify the drive shaft heat shield by cutting the shaded area in the picture to prevent the hose from rubbing up on the shield.



- Reinstall the heat shield and make sure there are enough clearance between the hose and the shield and the drive shaft.

\* Oil return hose to heat shield: 10mm

\* Oil return hose to drive shaft: 20mm

**Important!**

With out this proper clearance, there is a possibility of the return hose to fail and can cause fire and damage the engine.

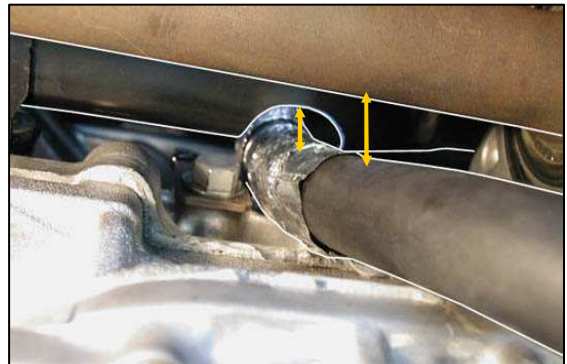

**3-9 Intercooler Core Installation**

Mount the side bracket of the intercooler to the sub-frame as show.

(Parts used #4,64,76)

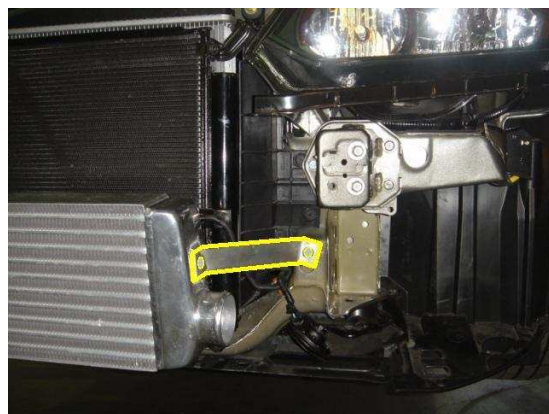



### 3-10 Horn Installation

- (4) Install the horn using provided aluminum spacer as shown.

(Parts used #66,77)

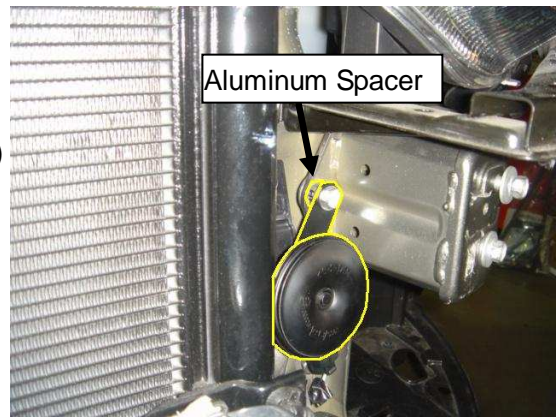

### 3-11 Compression Pipe Installation

- (1) Install Vacuum Fitting  $5\phi$ -1/8PT to the Compression pipe C-1.

(Parts used #7,28)

- (2) Install Compression pipe C-1 to the outlet of the turbo using the provided gasket and hardware.

(Parts used # 48, 78)

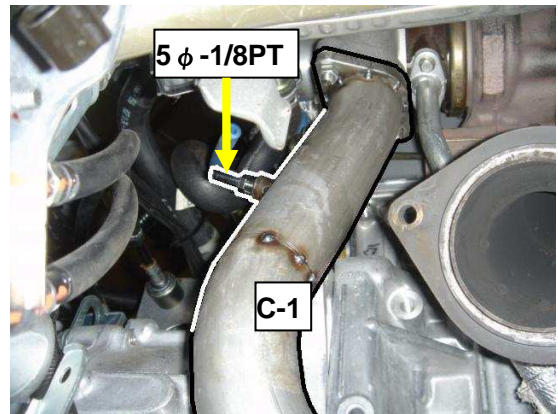

- (3) Connect the vacuum fitting  $5\phi$ -1/8PT to the actuator with the provided  $5\phi$  hose.

\* Secure all the vacuum hose with zip ties to prevent the hose from coming off the fitting.

(Parts used # 30)

- (4) Install compression pipe C-2~ C-4 between C-1 and intercooler. Using provided hose and clamps.

(Parts used #8,9,10,35,36,41,42)

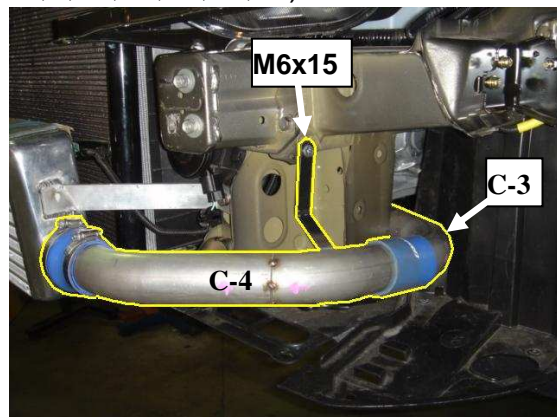
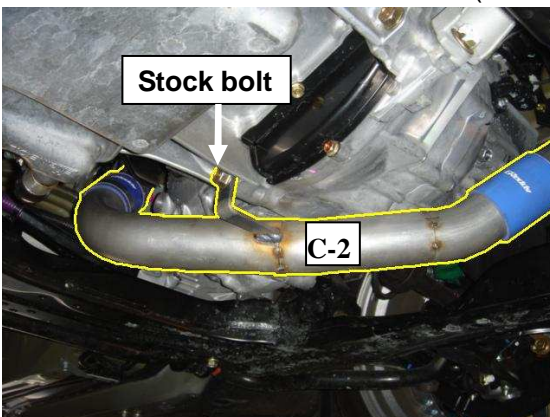

- (4) Install compression pipe C-5~ C-8 between intercooler and throttle body.  
Using provided hose and clamps.

(Parts used #11,12,13,14,34,36,37,41,42,43)

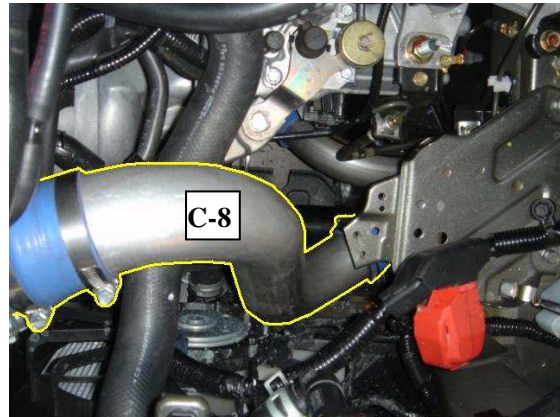
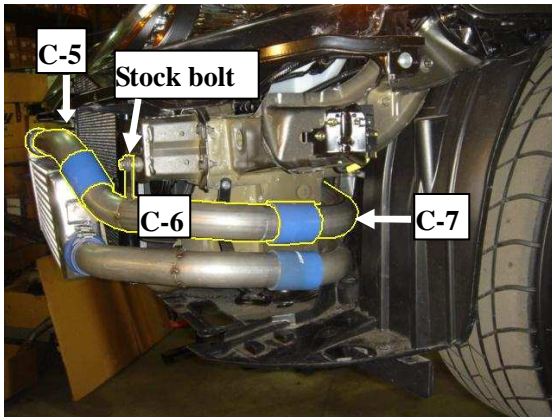

### 3-12 Airinx Installation

- (1) Remove the top bolt on the Airinx air filter and remove the outer frame, Install the provided hose adapter to the inner frame of the Airinx.

(Parts used #15,16)

- (2) Reinstall the outer frame and secure it with the top bolt.

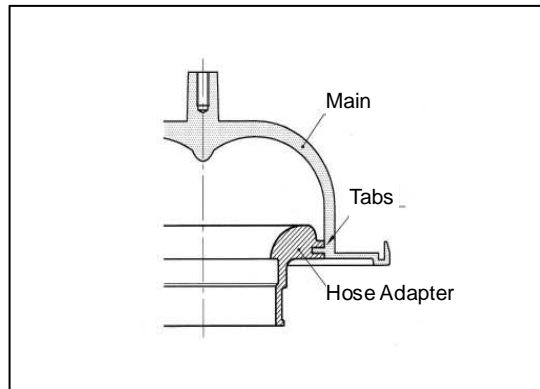

- (5) Remove the factory Airflow meter off from the air cleaner box and install the Airflow meter to the provided air flow meter adapter.

(Parts used #17,68)

- ※ The O-ring in the Airflow meter will be reused. Apply some grease on the O-ring on the Airflow meter, and make sure not to damage when installing.



- (6) Install stud bolts on to the inlet of the turbo, and install suction adapter using provided gasket.

(Parts used #6,47,76,)





- (7) Install the S-1. Secure the suction pipe bracket to the factory air cleaner box mounting point as shown.

(Parts used #5,35,42,71)

- (8) Install the Airinx and the adapter to suction Pipe S-1

\*Make sure that the Airinx and the piping does rub up on to the battery.

(Parts used #38,42,44)



- (8) Connect the blow by tube from the valve cover to the S-1 with the provided 18  $\phi$  hose and clamps. Also connect the air assist control valve to S-1 using provided 8  $\phi$  hose and clamps.

(Parts used #31,32,39,40)



### 3-13 Down Pipe Installation

- (1) Install three stud bolt on the turbine housing as shown.

(Parts used #79)



- (2) Check the fitment of the downpipe heat shield and install gasket on the catalytic converter end of the downpipe.

\*The heat shield will be reinstalled later once the downpipe is installed.

(Parts used #58, 69)



(3) Install the downpipe to the turbo using provided gasket and hardware.

\*Make sure that there is enough clearance between the downpipe and the oil pressure line. (Parts used #3,46,79,80)

(4) Reinstall the catalytic converter and reconnect the o2 sensor connectors.

\*Reuse factory hardware to bolt the cat back on but the bolts with springs will require the provided nuts. (Parts used #49,81)



### 3-14 Heat Shield Installation

(1) Install the turbine housing heat shield on to the downpipe using the provided M8 x 15mm bolts.

\*Make sure that there is enough clearance between the oil pressure line.

(Parts used #57,75)



(2) Install the down pipe heat shield on to the downpipe using the provided M6 x 10mm bolts.

(Parts used #58,69)



### 3-15 Fuel Injectors Installation

(1) Disconnect the fuel injector connectors and ground wire on the fuel delivery tube and remove the fuel delivery tube.

\*When removing the rail, use a rag to absorb the fuel that leaks out from the rail and hose.

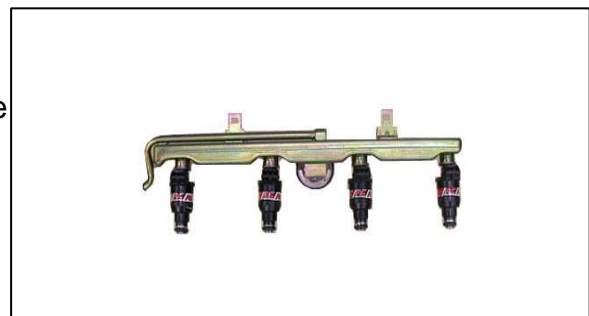



(2) Remove the injector clips off the rail, and remove the injectors.

(3) Install the new injectors on to the rail.

- \* Lube the o-rings on the injectors and make sure not to damage the o-ring when installing them in to the rail.

(Parts used # 55)

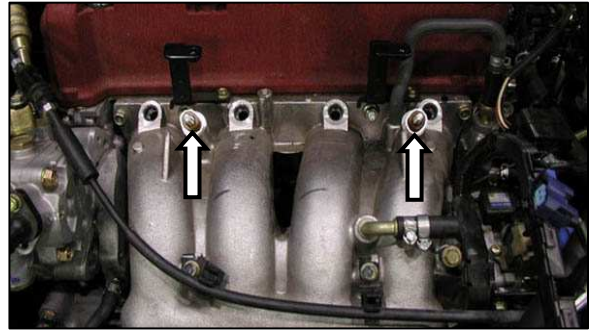

(4) Replace the stud bolts and spacers that holds the fuel rail down with the provided stud bolts and spacers.

(5) Install the fuel rail assembly to the intake manifold.

(6) Connect the injector harness using the provided plug-in harness.

(Parts used # 56)



### 3-16 Pressure Sensor Orifice Installation

(1) Remove the pressure sensor, then Install the pressure sensor orifice

(Parts used # 54)

(2) Reinstall the pressure sensor with the provided M6 washer.

(Parts used # 74)

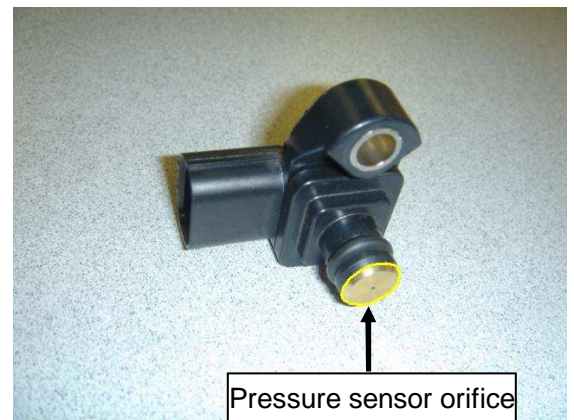

### 3-17 Starting the Engine

- (1) Refill the engine oil to factory spec.
- (2) Check all the hoses and wires connection and reconnect the battery.
- (3) Turn the ignition to “ON” position 2-3 times to get fuel pressure. Then, check the injectors and the fuel rail for any fuel leaks.

**\*Repair any fuel leaks before starting the engine. Starting the engine with a fuel leak can cause fire in the engine compartment and can be very dangerous.**

- (4) Remove the ECM fuse and crank the engine to get oil pressure to the turbo. (Until the oil light on the dash turns off) Check for any oil leaks, then reinstall the fuse and start the engine.
- (5) While idling, check for any oil, coolant, or air leaks.
- (6) After inspection, reinstall the under cover and other stock parts that was removed.
- (7) On the initial run, be sure to have a boost gauge to check the turbo-actuator setting. This turbo kit is preset to boost between  $0.4\text{kg/cm}^2$  to  $0.5\text{kg/cm}^2$  .  
It is very important that you monitor the boost pressure, and make sure not to over boost. Over boosting can cause engine damage.

This completes the Turbo Kit installation.

#### **Important!**

- **It is very important that you monitor the boost pressure, and make sure not to over boost. Over boosting can cause engine damage.**
- **GReddy Performance Products, Inc. is not responsible for any engine damage caused by over boosting (increased boost), modification to the kit, and/or misuse of the product. NO WARRANTY is offered.**
- **Due to lack of control over proper installation and use of this product,**  
NO WARRANTY is offered for this kit.

## **e-manage Ultimate Information**

### **Important!**

- **The e-manage included in this kit is preprogrammed for this turbo kit.**
- **Do not attempt to adjust any of the settings in the e-manage.**
- **Any adjustments made can cause damage to the e-manage, engine and the factory ECU.**

### **⌘ ACTIVE L.E.D.**

- When the ignition is turned on, it will illuminate and flash GREEN.
- When an error is detected it will flash RED.

### **§ INTERACTION L.E.D.**

- This will flash when there is a connection with PC.